

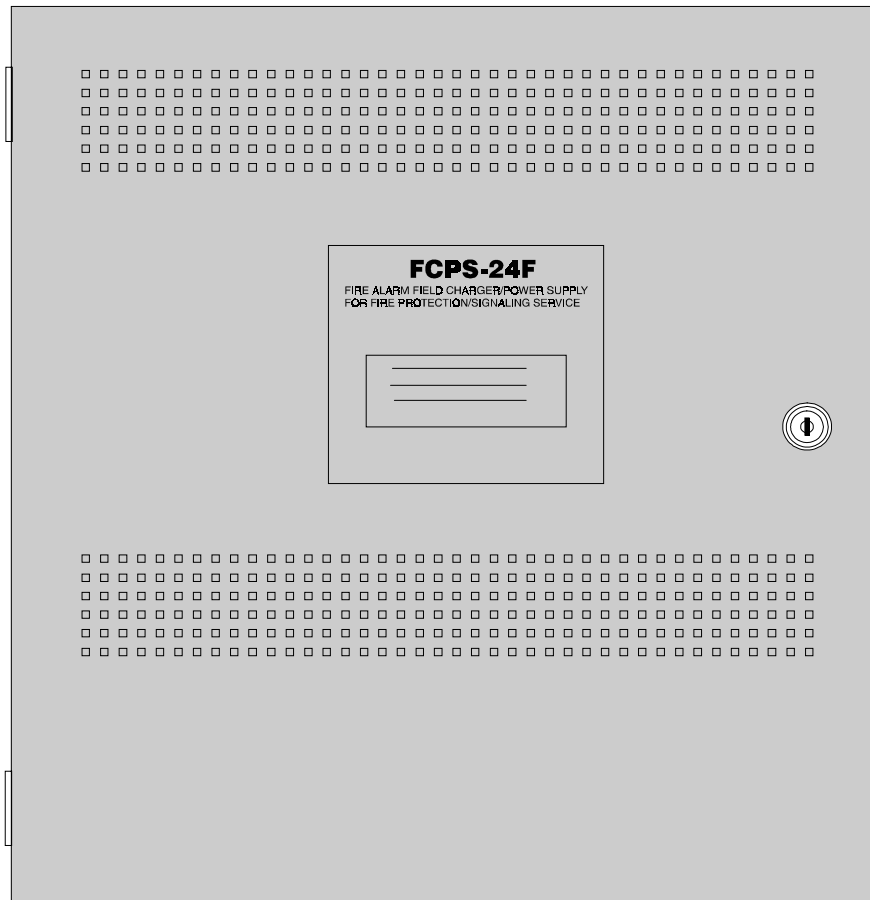

Fire·LITE[®] Alarms
INCORPORATED

12 Clintonville Road
Northford, CT 06472
203-484-7161
FAX: 203-484-7118



FCPS-24F/FCPS-24FE

Field Charger/Power Supply

Installation, Operation and Application Manual

Installation Precautions - Adherence to the following will aid in problem-free installation with long-term reliability:

WARNING - Several different sources of power can be connected to the fire alarm control panel. Disconnect all sources of power before servicing. Control unit and associated equipment may be damaged by removing and/or inserting cards, modules, or interconnecting cables while the unit is energized. Do not attempt to install, service, or operate this unit until this manual is read and understood.

CAUTION - *System Reacceptance Test after Software Changes:* To ensure proper system operation, this product must be tested in accordance with NFPA 72-1993 Chapter 7 after any programming operation or change in site-specific software. Reacceptance testing is required after any change, addition or deletion of system components, or after any modification, repair or adjustment to system hardware or wiring.

All components, circuits, system operations, or software functions known to be affected by a change must be 100% tested. In addition, to ensure that other operations are not inadvertently affected, at least 10% of initiating devices that are not directly affected by the change, up to a maximum of 50 devices, must also be tested and proper system operation verified.

This system meets NFPA requirements for operation at 0-49° C/32-120° F and at a relative humidity of 85% RH (non-condensing) at 30° C/86° F. However, the useful life of the system's standby batteries and the electronic components may be adversely affected by extreme temperature ranges and humidity. Therefore, it is recommended that this system and its peripherals be installed in an environment with a nominal room temperature of 15-27° C/60-80° F.

Verify that wire sizes are adequate for all initiating and indicating device loops. Most devices cannot tolerate more than a 10% I.R. drop from the specified device voltage.

Like all solid state electronic devices, this system may operate erratically or can be damaged when subjected to lightning induced transients. Although no system is completely immune from lightning transients and interferences, proper grounding will reduce susceptibility. Overhead or outside aerial wiring is not recommended, due to an increased susceptibility to nearby lightning strikes. Consult with the Technical Services Department if any problems are anticipated or encountered.

Disconnect AC power and batteries prior to removing or inserting circuit boards. Failure to do so can damage circuits.

Remove all electronic assemblies prior to any drilling, filing, reaming, or punching of the enclosure. When possible, make all cable entries from the sides or rear. Before making modifications, verify that they will not interfere with battery, transformer, and printed circuit board location.

Do not tighten screw terminals more than 9 in-lbs. Over tightening may damage threads, resulting in reduced terminal contact pressure and difficulty with screw terminal removal.

This system contains static-sensitive components. Always ground yourself with a proper wrist strap before handling any circuits so that static charges are removed from the body. Use static suppressive packaging to protect electronic assemblies removed from the unit.

Follow the instructions in the installation, operating, and programming manuals. These instructions must be followed to avoid damage to the control panel and associated equipment. FACP operation and reliability depend upon proper installation.

Fire Alarm System Limitations

While installing a fire alarm system may make lower insurance rates possible, it is not a substitute for fire insurance!

An automatic fire alarm system - typically made up of smoke detectors, heat detectors, manual pull stations, audible warning devices, and a fire alarm control with remote notification capability can provide early warning of a developing fire. Such a system, however, does not assure protection against property damage or loss of life resulting from a fire.

Any fire alarm system may fail for a variety of reasons:

Smoke detectors may not sense fire where smoke cannot reach the detectors such as in chimneys, in walls, or roofs, or on the other side of closed doors. Smoke detectors also may not sense a fire on another level or floor of a building. A second floor detector, for example, may not sense a first floor or basement fire. Furthermore, all types of smoke detectors - both ionization and photoelectric types, have sensing limitations. No type of smoke detector can sense every kind of fire caused by carelessness and safety hazards like smoking in bed, violent explosions, escaping gas, improper storage of flammable materials, overloaded electrical circuits, children playing with matches, or arson.

IMPORTANT! *Smoke detectors must be installed in the same room as the control panel and in rooms used by the system for the connection of alarm transmission wiring, communications, signaling, and/or power.* If detectors are not so located, a developing fire may damage the alarm system, crippling its ability to report a fire.

Audible warning devices such as bells may not alert people if these devices are located on the other side of closed or partly open doors or are located on another floor of a building.

A fire alarm system will not operate without any electrical power. If AC power fails, the system will operate from standby batteries only for a specified time.

Rate-of-Rise heat detectors may be subject to reduced sensitivity over time. For this reason, the rate-of-rise feature of each detector should be tested at least once per year by a qualified fire protection specialist.

Equipment used in the system may not be technically compatible with the control. It is essential to use only equipment listed for service with your control panel.

Telephone lines needed to transmit alarm signals from a premise to a central monitoring station may be out of service or temporarily disabled.

The most common cause of fire alarm malfunctions, however, is inadequate maintenance. All devices and system wiring should be tested and maintained by professional fire alarm installers following written procedures supplied with each device. System inspection and testing should be scheduled monthly or as required by National and/or local fire codes. Adequate written records of all inspections should be kept.

FCC Warning

WARNING: This equipment generates, uses, and can radiate radio frequency energy and if not installed and used in accordance with the instruction manual, may cause interference to radio communications. It has been tested and found to comply with the limits for class A computing device pursuant to Subpart B of Part 15 of FCC Rules, which is designed to provide reasonable protection against such interference when operated in a commercial environment. Operation of this equipment in a residential area is likely to cause interference, in which case the user will be required to correct the interference at his own expense.

Canadian Requirements

This digital apparatus does not exceed the Class A limits for radiation noise emissions from digital apparatus set out in the Radio Interference Regulations of the Canadian Department of Communications.

Le présent appareil numérique n'émet pas de bruits radioélectriques dépassant les limites applicables aux appareils numériques de la classe A prescrites dans le Règlement sur le brouillage radioélectrique édicté par le ministère des Communications du Canada.

Table of Contents

Chapter 1	System Overview	4
	Section 1.0: Description	4
	Section 1.1: Features	4
	Section 1.2: LED Indicators	4
	Section 1.3: Configuration Jumpers, Resistors & Diodes	5
	Section 1.4: Optional Device MPM-4F Description	5
	Section 1.5: Specifications	6
	Section 1.6: Installation Standards and Codes	6
	Figure 1-1: FCPS Board Layout	7
	Section 1.7: General	8
	Figure 1-2: Simplified FCPS Block Diagram	8
Chapter 2	Installation	9
	Section 2.0: General	9
	Section 2.1: Backbox Mounting	9
	Section 2.2: MPM-4F Installation	9
	Figure 2-1: Backbox Mounting Dimensions	10
	Figure 2-2: MPM-4F Installation Diagram	10
	Section 2.3: UL Power-limited Wiring Requirements	11
	Figure 2-3: Power-limited Wiring Requirements	11
Chapter 3	Operation	12
	Section 3.0: Trouble Supervision	12
	Section 3.1: Supervision via FACP Notification Appliance Ckt	12
	Figure 3-1: Wiring Diagram for Multiple FCPS Units	13
	Section 3.2: Full Supervision via Input Circuit or Monitor Module	13
Chapter 4	Special Applications	14
	Section 4.0: Specific Applications	14
	Section 4.1: Controlling Four Outputs from One Input	14
	Figure 4-1a: Control Module Application (Style Y)	14
	Figure 4-1b: Control Module Application (Style Z)	15
	Section 4.2: Controlling Four Outputs from Two NAC Inputs	16
	Figure 4-2: Two Inputs Controlling Four Outputs	16
	Section 4.3: Controlling Four Outputs from One NAC Input	17
	Figure 4-3: One NAC Input Controlling Four Outputs	17
	Section 4.4: Stand-alone Power Supply - Nonresettable	18
	Figure 4-4: Stand-alone Power Supply	18
	Section 4.5: Remote Power Supply resettable/Nonresettable	19
	Figure 4-5: One NAC Input - Resettable & Nonresettable	19
	Section 4.6: Control Module Activation of Output Circuits	20
	Figure 4-6: Control Module Activation of Outputs	20
	Section 4.7: Door Release Service Application	21
	Figure 4-7: Using the FCPS with 24 VDC Door Holders	21
Chapter 5	Battery Calculations	22
	Section 5.0: External Device Power	22
	Section 5.1: Device Standby Current Draw	22
	Table 5-1: Load in Standby	22
	Table 5-2: Load in Alarm	23
	Table 5-3: Secondary Power Source Calculations	24

CHAPTER ONE

System Overview

1.0 Description

The FCPS-24F is a compact, cost-effective, remote power supply and battery charger. This remote power supply consists of a filtered 24 VDC output that may be configured to drive four Notification Appliance Circuits (two Style Y or Style Z, and two Style Y only). Alternately, the four Notification Appliance Circuits may be configured as resettable or nonresettable power outputs. The FCPS-24FE offers the same features as the FCPS-24F but allows connection to 220/240 VAC input.

1.1 Features

- Self contained in lockable cabinet.
- 24 VDC remote power supply.
- Outputs are completely power-limited.
- Two optically-isolated input/control circuits.
- Two Style Y/Style Z Notification Appliance Circuits.
- Two additional circuits that are configurable as Style Y Notification Appliance Circuits.
- Alternately, all four or a combination of the circuits may be configured as 24 VDC power outputs.
- Output power circuits may be configured as resettable or nonresettable.
- 3.0 amps maximum current available for any one output circuit.
- 4.0 amps total of continuous current available.
- 6.0 amps maximum short term (one hour maximum) current can be provided.
- Fully filtered power output.
- Integral supervised battery charger.
- Up to 7.0 AH batteries in remote power supply cabinet.
- Fully supervised power supply, battery, and Notification Appliance Circuits.
- Selectable Earth Fault detection.
- Delay of AC loss reporting (8 or 16 hours).
- Fixed terminal blocks for field wiring that are capable of accepting up to 12 AWG wire.
- Normally closed trouble contact.
- MPM-4F optional charger Voltmeter/Ammeter.

1.2 LED Indicators

- AC power on (green).
- AC Fail/Earth Fault (yellow).
- Battery/charger trouble (yellow).
- Circuits field wiring faults (yellow). Circuits 1 through 4 are supervised for shorts and opens during the inactive state.

Note: Unless otherwise specified, the term 'FCPS' shall be used in this manual, where appropriate, to refer to both the FCPS-24F and FCPS-24FE power supplies.

1.3 Configuration Jumpers, Resistors & Diodes

- *Battery Charging Circuit (JP1)* - To disable local battery charger, cut jumper JP1 (an external charger listed for fire protective signaling is required).
- *Optional MPM-4F Voltmeter/Ammeter* - To enable charger current measurement with MPM-4F, cut JP1 and plug-in MPM-4F connector to the P3 header.
- *Earth Fault Detection (R27)* - To disable local earth fault detection, cut resistor R27. Note that Earth Fault detection is required in Canada.
- *Trouble Supervision (R63, D31, JP2)* - These components are used to configure local trouble reporting through the remote power supply trouble contact. Refer to the Trouble Supervision section for a complete description.
- *Delay AC Loss Reporting (R76 and R134)* - When a Digital Alarm Communicator Transmitter (DACT) is installed in the FACP, the reporting of an AC loss condition to a central station must be delayed. With 24-hour battery standby, cut R134 to delay AC loss reporting for 8 hours. With 60-hour battery standby, cut R76 and R134 to delay the report by 16 hours.
- *Disable Resettable Power Function for Output Circuit #2 or #4 (R175 and R176)*.
Cut R175 to make Output #2 nonresettable power.
Cut R176 to make Output #4 nonresettable power.

1.4 Optional Device MPM-4F Description

The MPM-4F is used for:

- Monitoring battery/charger voltage (Voltmeter)
- Monitoring charger current (Ammeter)

The MPM-4F is most commonly required in military installations. It consists of two analog edge meters (a voltmeter and an ammeter) which connects to the P3 Header.

The voltmeter measures battery and charger voltage. It is electrically connected across battery terminals TB2.1 and TB2.2. When the battery is disconnected, the voltmeter measures charger voltage only. Periodically (approximately 2 seconds every 40 seconds) the FCPS performs a battery test by disabling the charger. During this period, charger current that is measured by the ammeter, drops to zero. The voltmeter now only measures the battery voltage. Battery voltage ranges from 20.4 (low battery) to 27.6 (fully charged).

The ammeter is electrically connected across JP1 and measures current delivered from the charger to the battery, except for the period during the battery test. Charger current is normally limited to 250mA. In order to enable the ammeter, JP1 must be cut.

1.5 Specifications

Primary (AC) Power

- FCPS-24F: 120 VAC 50/60 Hz, 2.0 A maximum.
- FCPS-24FE: 220/240 VAC 50/60 Hz, 1.0 A maximum.

- Wire size: minimum #14 AWG with 600V insulation

Control Input Circuit

- Trigger Input Voltage - 9 to 32 VDC
- Input Current Draw in Alarm Polarity
 - 16 - 32V 2.0mA per input
 - 9 - 16V 1.0mA per input

Trouble Contact Rating

- 5 amps at 24VDC

Output Circuits (19.1 - 26.4 VDC, filtered)

- 3.0 amps maximum for any one circuit
- 4.0 amps maximum total continuous current for all outputs
- 6.0 amps maximum total short term (one hour maximum) current for all outputs

Auxiliary Power Output

- Specific Application Power - 45 mA Short Circuit.

Secondary Power (Battery) Charging Circuit

- Supports lead acid batteries only.
- Float Charge Voltage: 27.6V
- Maximum Charge Current: 250 mA
- Maximum Battery Capacity: 7.0 AH

1.6 Installation Standards and Codes

The FCPS complies with the following standards:

NFPA 72-1993 National Fire Alarm Code

Underwriters Laboratories:

- UL 864 Standard for Control Units for Fire Alarm Systems
- UL 1481 Power Supplies for Fire Alarm Systems

In addition, the installer should be familiar with the following standards:

- NEC Article 300 Wiring Methods
- NEC Article 760 Fire Protective Signaling Systems
- Applicable Local and State Building Codes
- Requirements of the Local Authority Having Jurisdiction

Other documents supporting Fire•Lite Alarms products referenced in this manual are listed below.

- Device Compatibility Document 15384
- The MS-9200 Instruction Manual, Document 15668
- The Sensiscan 2000 Installation Manual, Document 15017

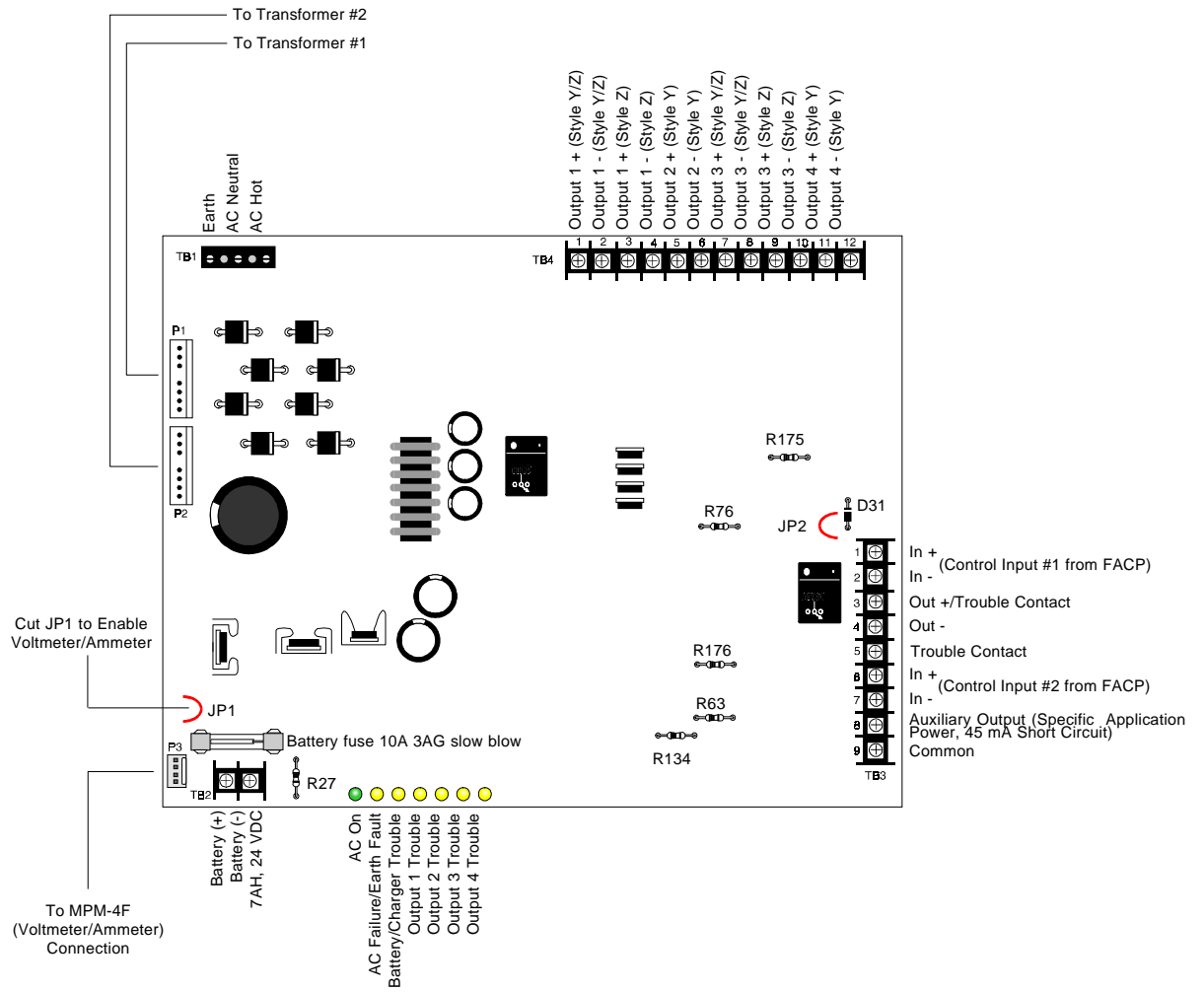

Figure 1-1: FCPS Board Layout

1.7 General

The FCPS may be used in a number of different applications. It may be used as a remotely-mounted power supply and battery charger where it can power up to four, coded or non-coded, Notification Appliance Circuits. Alternately, any or all of these circuits may be used as 24 VDC output circuits capable of powering four wire smoke detectors or any device that requires filtered power. These circuits may be configured as resettable or nonresettable outputs.

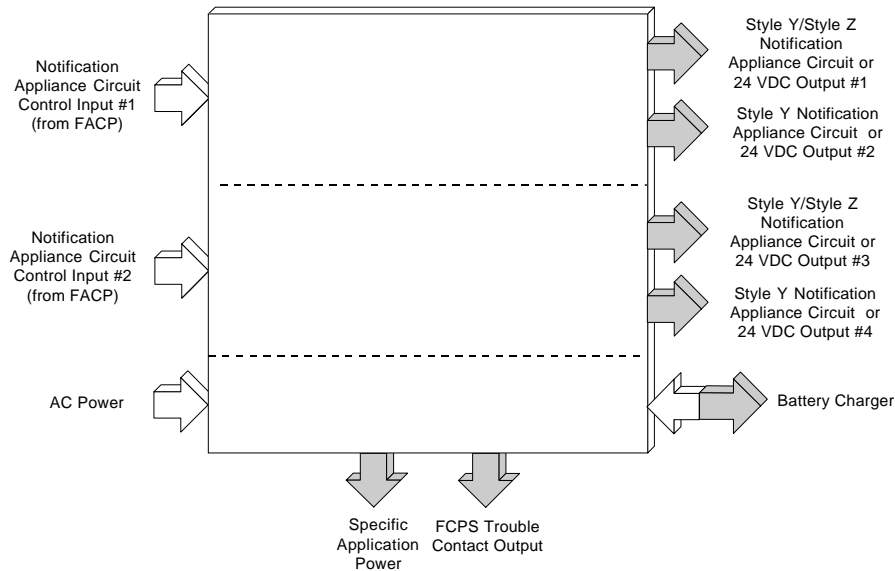

Figure 1-2: Simplified FCPS Block Diagram

One of the most common applications for the FCPS remote power supply utilizes the NAC repeater feature. In this application, one or two Notification Appliance Circuits (NAC) are connected from the main FACP NAC output(s) to the remote power supply Control Input circuits. When these Control Input circuits activate (due to reverse polarity of the NAC output), the power supply will activate its corresponding outputs. NAC Control Input #1 controls power supply output circuits #1 and #2. NAC Control Input #2 controls output circuits #3 and #4 (refer to Figure 4-2).

During the inactive state, the remote power supply supervises its NAC field wiring for short and open circuits. If a fault is detected, the supply will enter a trouble condition and illuminate the corresponding NAC trouble LED (Output Circuits 1-4). However, once the Notification Appliance Circuits are activated, the supervision is disabled and the circuits are no longer supervised. Supervision of other power supply faults such as low battery, Earth Fault, AC loss and battery charger failure will continue and may be monitored via the trouble relay contact.

If a specific application requires that all four outputs activate at the same time, only one NAC control input from the FACP is necessary. For this application, the Notification Appliance Circuit from the FACP is wired into NAC Control Input #1 of the remote supply and then a pair of wires are connected from NAC Control Output #1 to NAC Control Input #2 (refer to Figure 4-3).

CHAPTER TWO:

Installation

2.0 General

Carefully unpack the system and check for shipping damage. Select a location for the cabinet that is in a clean, dry, vibration-free area where extreme temperatures are not encountered. The area should be readily accessible with sufficient room to easily install and maintain the panel. Locate the top of the cabinet approximately five feet above the floor with the hinge mounting on the left.

Determine the number of conductors required for the devices to be installed and determine the appropriate knockouts. All wiring must be in accordance with the National and/or Local codes for fire alarm systems.

2.1 Backbox Mounting

- 1) Remove the main PC board assembly by unscrewing the four screws in the corners of the board. Two permanent standoffs support the board in the center.

Set the board aside in a safe, clean place. Avoid static discharge which may damage the board.

- 2) Mark and predrill holes for the top two keyhole mounting bolts.
- 3) Install two upper fasteners in the wall with the screw heads protruding approximately 1/4".
- 4) Using the upper keyholes, mount the backbox over the two screws.
- 5) Mark the lower two holes, remove backbox and drill mounting holes.
- 6) Mount backbox, install remaining fasteners and tighten.
- 7) When the location is dry and free of construction dust, reinstall the main PC board (refer to Figure 2.1).

2.2 MPM-4F Installation

- 1) Cut Jumper JP1.
- 2) With a nut driver, loosen bottom nut of the lower transformer.
- 3) Slide in MPM-4F meter bracket between transformer and nut.
- 4) Fasten the nut.
- 5) Connect the meter assembly cable to P3 header (refer to Figure 2.2).

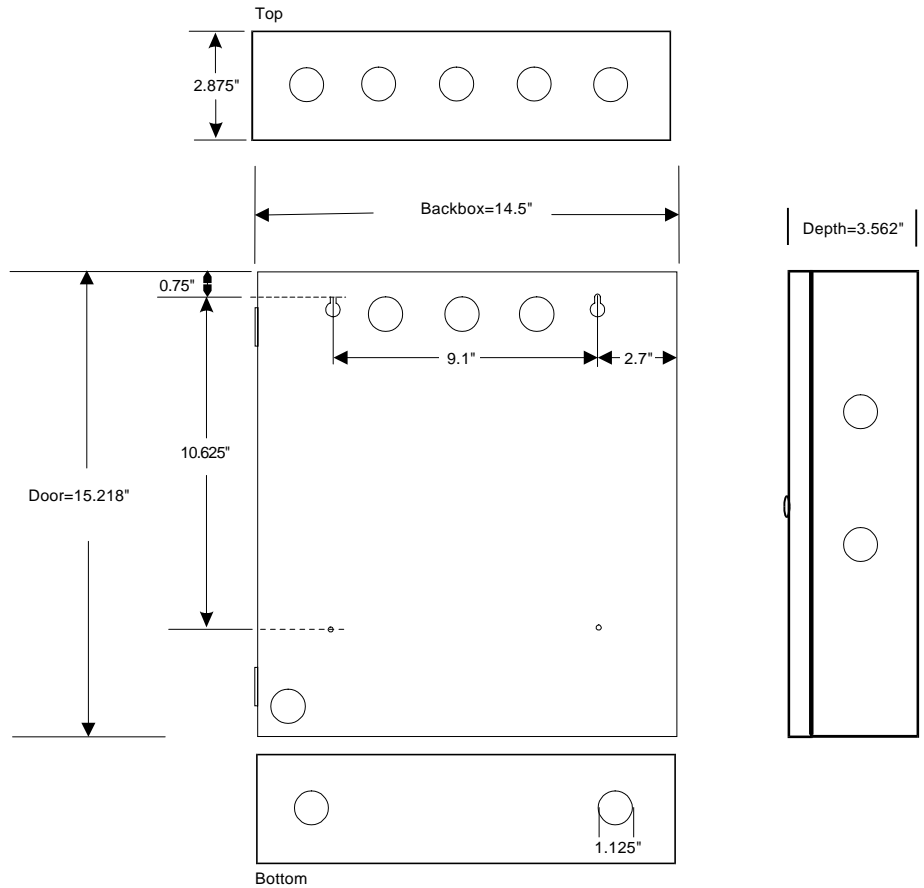

Figure 2-1: Backbox Mounting Dimensions

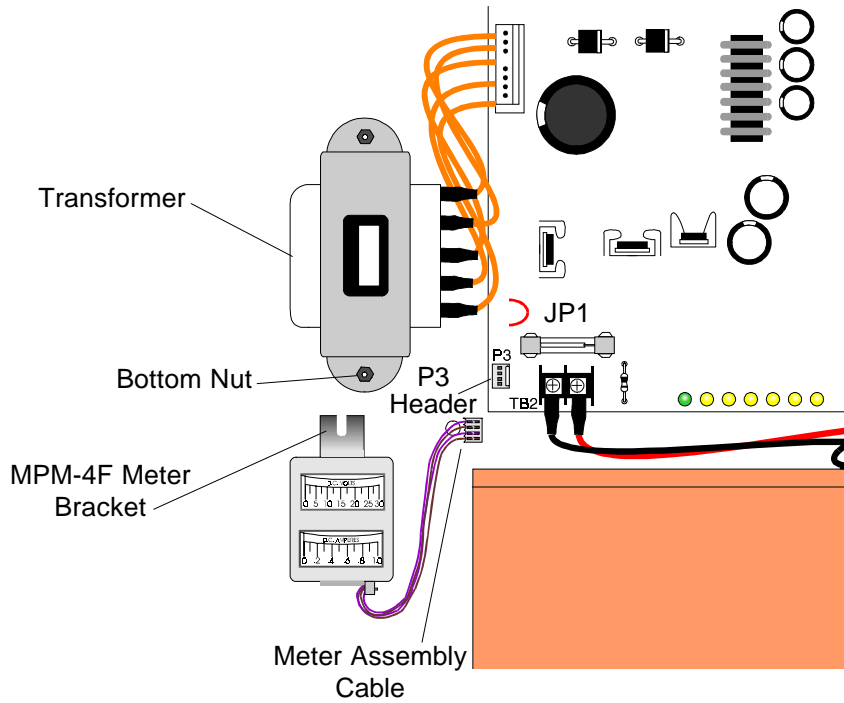

Figure 2-2: MPM-4F Installation Diagram

2.3 UL Power-limited Wiring Requirements

Power-limited and nonpower-limited circuit wiring must remain separated in the cabinet. All power-limited circuit wiring must remain at least 0.25" away from any nonpower-limited circuit wiring. Furthermore, all power-limited circuit wiring and nonpower-limited circuit wiring must enter and exit the cabinet through different conduits. One such example of this is shown below. Your specific application may require different conduit knockouts to be used. Any conduit knockouts may be used. For power-limited applications, use of conduit is optional.

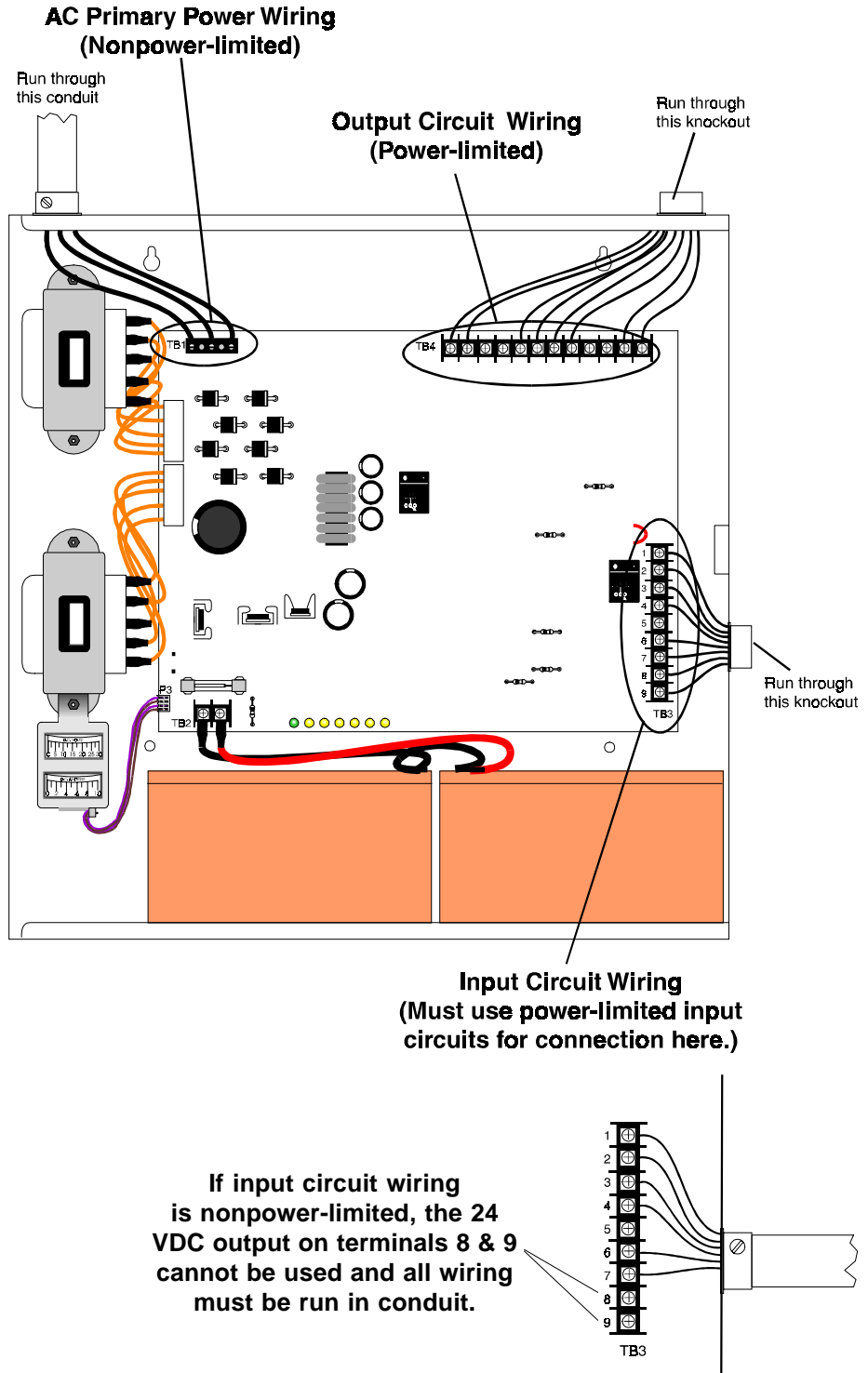

Figure 2-3: Power-limited Wiring Example

CHAPTER THREE:

Operation

3.0 Trouble Supervision

When a trouble occurs on the FCPS, it must also appear on the main Fire Alarm Control Panel. The remote power supply has two ways of sending this trouble signal to the FACP. *However, only one of the trouble reporting methods may be used.*

3.1 Supervision via FACP Notification Appliance Circuit

Supervision of FACP to FCPS Wiring

The FACP supervises the connection between itself and the FCPS via an End-of-Line Resistor (ELR). The ELR must be installed at the FCPS end of the circuit. If no additional devices are connected to these terminals, the ELR must be connected directly across terminals 3 and 4. An open or short on this circuit will be detected at the FACP as an NAC trouble (refer to Figure 4-2).

Supervision of FCPS Faults

The FACP will detect these power supply faults as an open circuit condition on its NAC. Any of the following conditions will cause an internal trouble contact on the FCPS to open provided the FACP NAC is not in alarm:

- a) A field wiring fault on any output of the power supply during the inactive state.
- b) An AC fail condition at the power supply (may be delayed depending on R134).
- c) A battery fail condition at the power supply.
- d) Battery charger fail.
- e) Earth Fault condition.

Any power supply trouble will break the connection between the FACP and the ELR provided the FACP's NAC is not in alarm. The FACP's ELR must be placed after the last NAC appliance connected to FCPS terminals 3 & 4 or, if no appliances are connected to these terminals, the ELR must be connected directly across terminals 3 & 4 (refer to Figure 4-2 and 4-3).

Note: Circuit Control Input #2 cannot be used to supervise the power supply but an ELR is still required for FACP wiring supervision.

Multiple FCPS-24 Controlled by a Single NAC

In a standby condition with no troubles, the FACP NAC output produces a negative voltage which forces current to flow through the ELR. If any FCPS is in a trouble state, that FCPS will open connection between input terminal TB3.1 and TB3.3. This will cause a break in the NAC, which will then be reported by the FACP as a NAC open trouble.

The alarm polarity sent by the FACP will always force restoration of connection between TB3.1 and TB3.3 on all FCPS units, unless this function was disabled by cutting resistor R63 or by the removal of JP2 and D31 (refer to Figure 3-1).

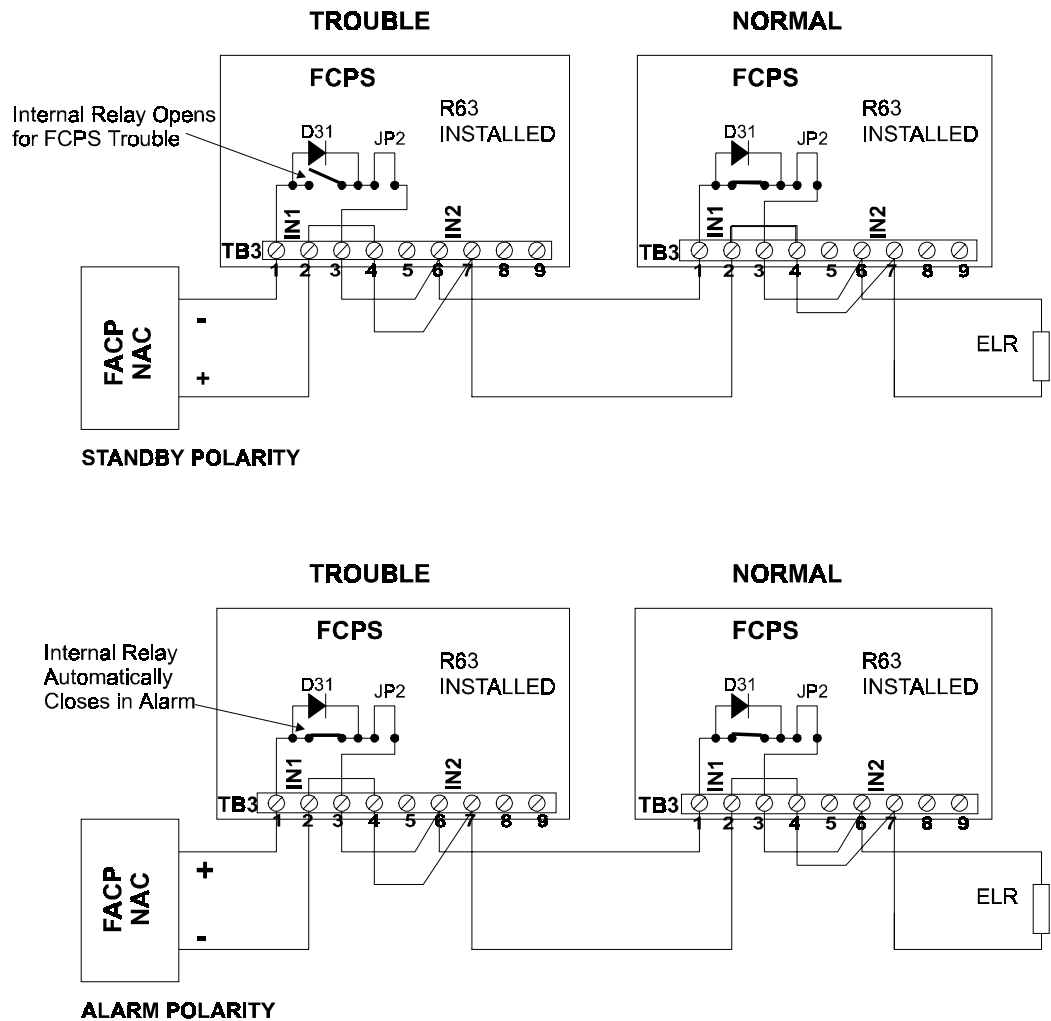

Figure 3-1: Wiring Diagram of Multiple FCPS Units

3.2 Full Supervision via Input Circuit or Monitor Module

This method of supervision provides FACP annunciation of the FCPS trouble condition even if the FACP is in alarm. The FACP's Notification Appliance Circuit is not used for supervision. Cut diode D31, jumper JP2 and resistor R63. Monitor FCPS trouble contacts at terminals TB3-3 and TB3-5. Any trouble condition listed above will trigger the internal trouble contact regardless of voltage polarity on the input 1. An addressable monitor module or any FACP input circuit may be used to track the condition of the trouble contact (refer to Figures 4-4, 4-5 and 4-6).

CHAPTER FOUR: Special Applications

4.0 Specific Applications

4.1 Controlling Four Outputs from One Input

All four FCPS output circuits can be controlled from one control input, which in Figures 4-1a and 4-1b is illustrated as a control module. The control module can be powered from the FCPS auxiliary 24 VDC power output (TB3 terminals 8 & 9) and supervised by an EOL relay.

All four remote power supply outputs are shown as Notification Appliance Circuits. Alternately, circuits 2 and/or 4 could be used as nonresettable power output circuits which is accomplished by cutting resistors R175 for circuit 2 or R176 for circuit 4 (refer to Figures 4-4 and 4-5).

The control module is shown to demonstrate the use of the power supply on a multiplexed system. The control module could be replaced with any circuit capable of polarity reversal. Note that Figure 4-1a shows Style Y configuration and Figure 4-1b shows Style Z configuration.

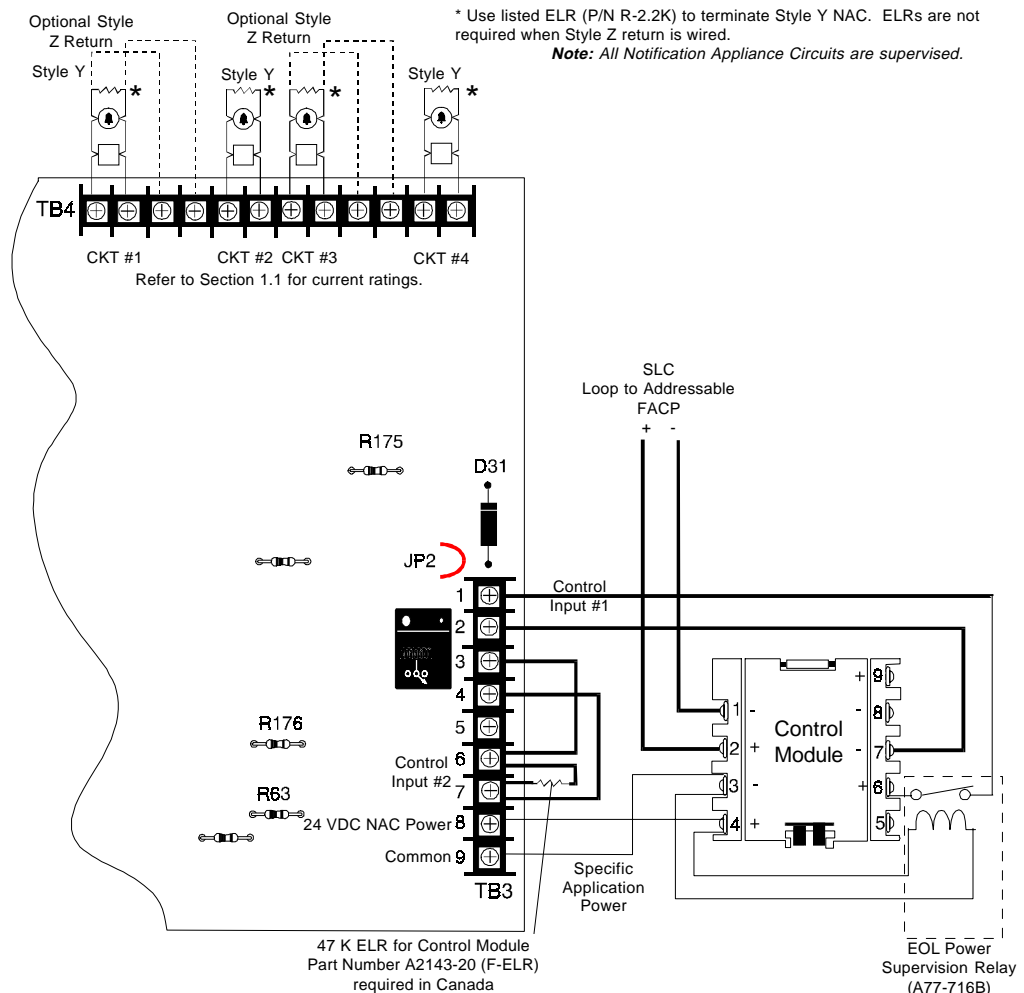

Figure 4-1a: Control Module Application (Style Y)

Notes: (The following notes apply to Figure 4-1a)

- 1) When the remote power supply is in an inactive state (control module not active), a trouble on the power supply will result in an open circuit condition on the control module. As an alternative to monitor for trouble conditions, the trouble contact on the FCPS may be used for independent trouble monitoring (refer to Figures 4-5 and 4-6).
- 2) Do not loop wires under screw terminals. Break wires to maintain proper supervision.
- 3) For Style Y application, an ELR must be installed between Terminals 6 and 7 for control module wiring supervision (the ELR value is dependent on the module employed).
- 4) Supervise the wiring between the FCPS 24 VDC output on TB3 terminals 8 & 9 and the control module with an EOL relay (A77-716B).
- 5) For a list of compatible devices, refer to the Fire-Lite Device Compatibility Document.

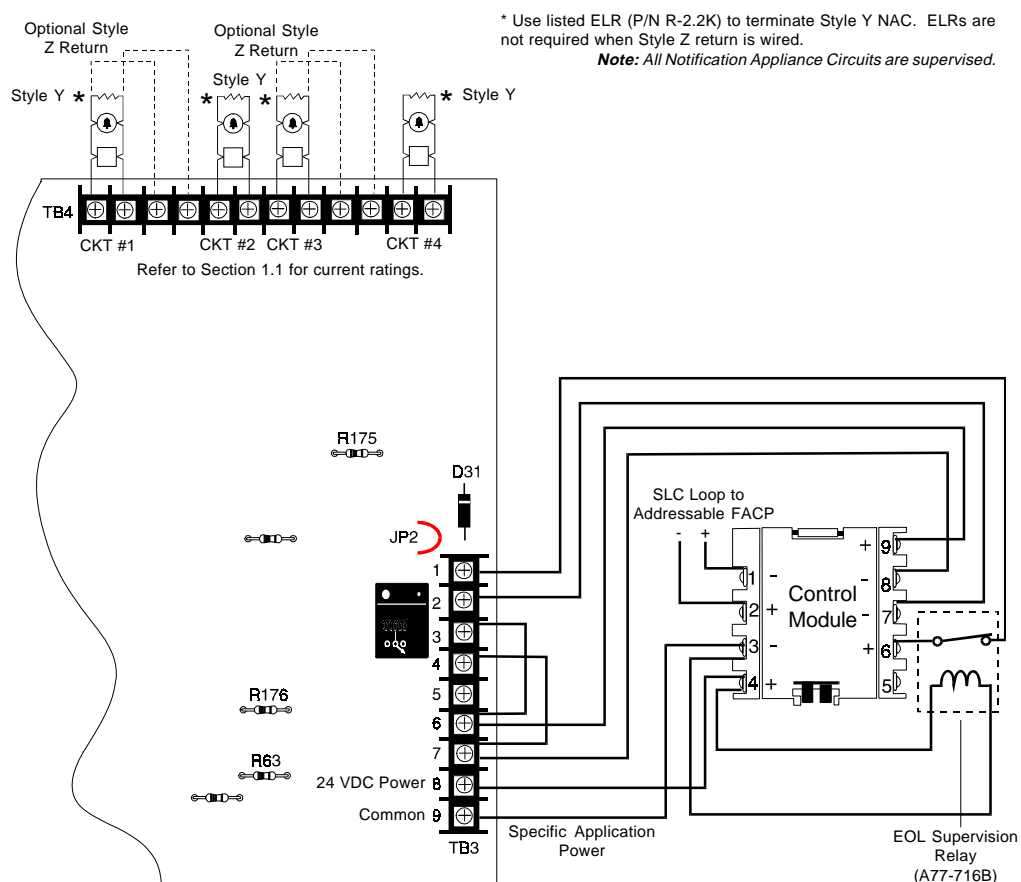

Figure 4-1b: Control Module Application (Style Z)

Notes: (The following notes apply to Figure 4-1b)

- 1) When the remote power supply is in an inactive state (control module not active), a trouble on the power supply will result in an open circuit condition on the control module. As an alternative to monitor for trouble conditions, the trouble contact on the FCPS may be used for independent trouble monitoring (refer to Figures 4-5 and 4-6).
- 2) Do not loop wires under screw terminals. Break wires to maintain proper supervision.
- 3) Supervise the wiring between the FCPS 24 VDC output on TB3 terminals 8 & 9 and the control module with an EOL relay (A77-716B).
- 4) For a list of compatible devices, refer to the Fire-Lite Device Compatibility Document.

4.2 Controlling Four Outputs from Two NAC Inputs

This application expands notification appliance power by an additional 6.0 amps. Use up to four Class B (Style Y) outputs or two Class A (Style Z) and two Class B (Style Y) outputs. In this example, the FACP Notification Appliance Circuits will activate the remote power supply when reverse polarity activation occurs due to an alarm condition. NAC #1 will activate FCPS outputs 1 & 2 and NAC #2 will activate outputs 3 & 4. Trouble conditions on the power supply are monitored by the FACP via Notification Appliance Circuit #1. Since Input #1 can monitor troubles, it is advisable to control silenceable notification appliances with this circuit and nonsilenceable or resettable smoke detector power with Control Input #2.

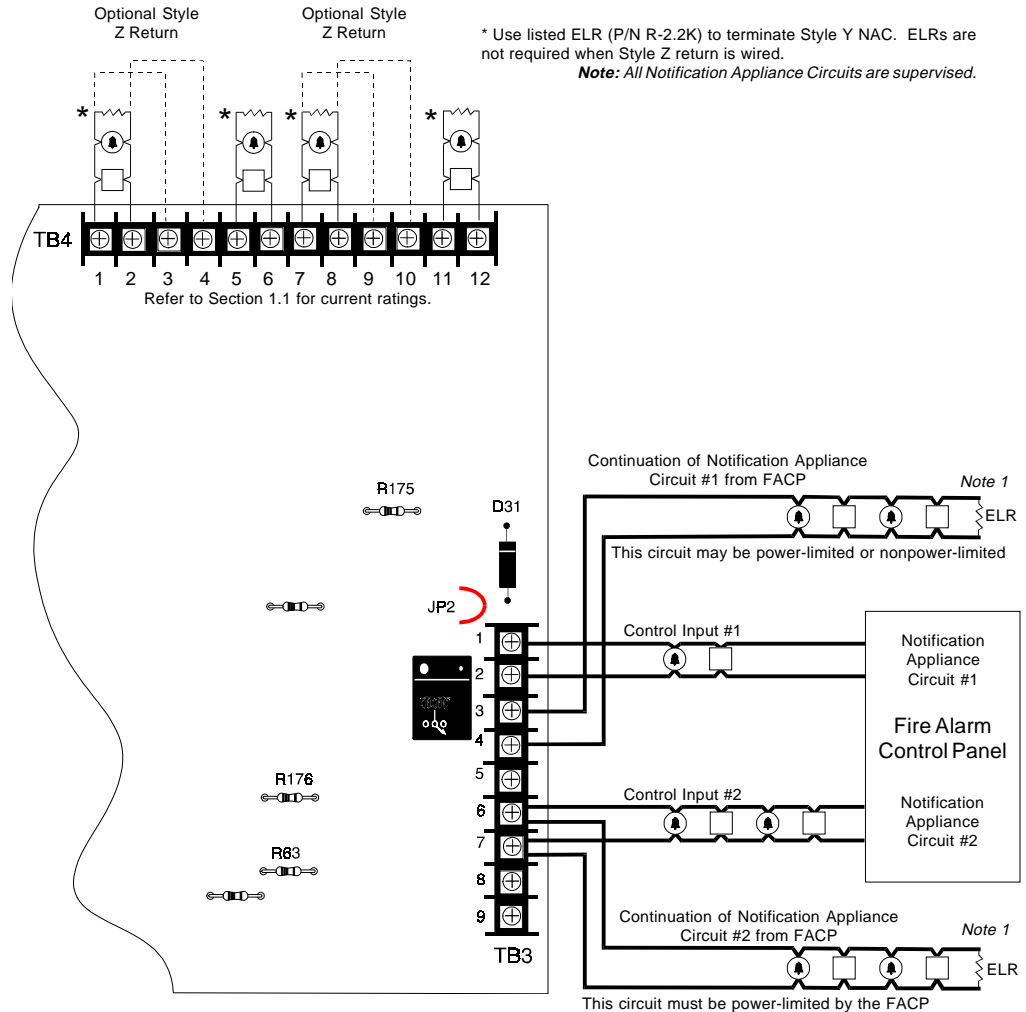

Notes:

- 1) ELRs must be used on the Notification Appliance Circuits. Refer to the respective FACP installation manual for corresponding ELR value. If no devices are installed on a branch, dummy load the circuit with the ELR.
- 2) Do not loop wires under screw terminals. Break wires to maintain proper supervision.
- 3) For a list of compatible devices, refer to the Fire-Lite Device Compatibility Document.

Figure 4-2: Two Inputs Controlling Four Outputs

4.3 Controlling Four Outputs from One NAC Input

This application expands notification appliance power by an additional 6.0 amps. Use up to four Class B (Style Y) outputs or two Class A (Style Z) and two Class B (Style Y) outputs. In this example, the FACP Notification Appliance Circuit will activate the remote power supply when reverse polarity activation occurs. Trouble conditions on the power supply are sensed by the FACP through the Notification Appliance Circuit #1. Since Control Input #1 can monitor the NAC and power supply for troubles only in the nonactive state, it is advisable to control silenceable notification appliances with this circuit and nonsilenceable or nonresettable power with Control Input #2.

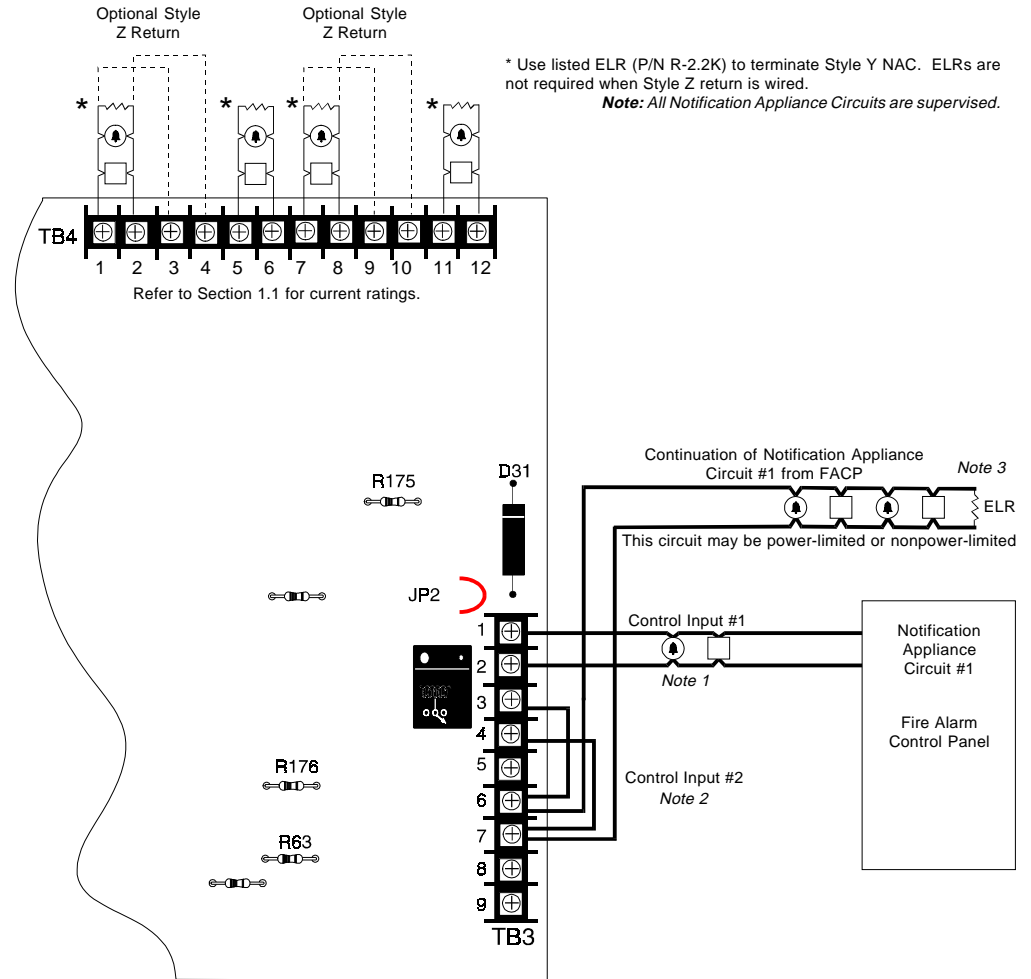

Notes:

- 1) Connect the Notification Appliance Circuit originating from the FACP to TB3 terminals 1 and 2 on the FCPS.
- 2) Jumper TB3 Terminal 3 to Terminal 6 and Terminal 4 to Terminal 7. This allows a single Control Input to control the four FCPS outputs. Install the ELR across terminals 6 and 7 to supervise the Notification Appliance Circuit originating from the FACP as well as the jumpers. Refer to the respective FACP installation manual for corresponding ELR value.
- 3) If additional notification appliances are installed, remove the ELR from FCPS TB3 terminals 6 and 7, connect the devices to FCPS terminals 6 and 7 and install the ELR after the last device.
- 4) Do not loop wires under screw terminals. Break wires to maintain proper supervision.
- 5) For a list of compatible devices, refer to Fire-Lite Device Compatibility Document.

Figure 4-3: One NAC Input Controlling Four Outputs

4.4 Stand-Alone Power Supply for Nonresettable Outputs

The FCPS may be used as a remote stand-alone power supply to provide up to an additional 4.0 amps of power to any devices that require filtered, regulated, nonresettable power. A nonresettable output is created by jumpering the auxiliary 24VDC output [TB3-8 (+) & TB3-9 (-)] to Control Input circuits 1 and 2. For addressable panel applications, a monitor module may be used to monitor the trouble contact of the FCPS. If the FCPS enters a trouble condition the normally closed contact will open. Cut JP2, R63 and D31 for this application.

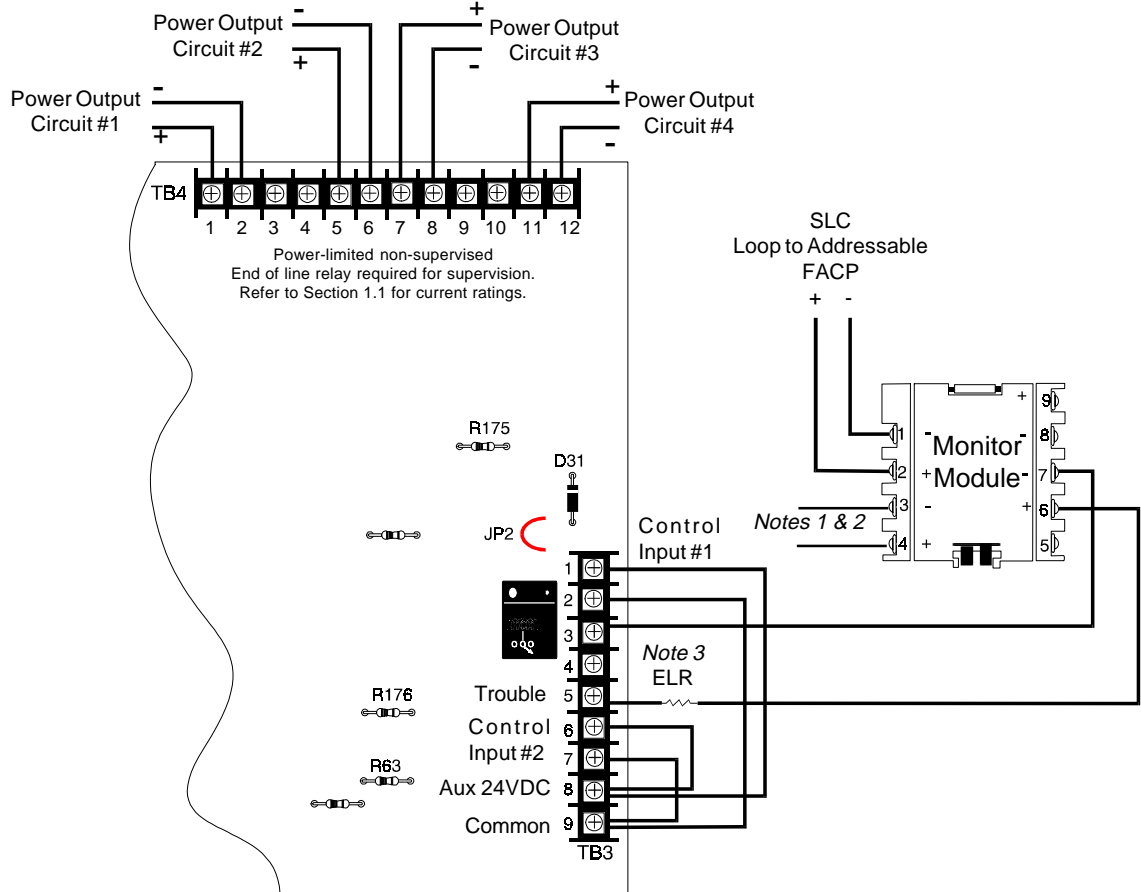

Notes:

- 1) If an addressable M302 Monitor Module is employed to monitor the trouble contacts of the remote power supply, the module must be supplied with separate 24 VDC power. This power is required so that the module may supervise the connection to the trouble contacts of the power supply.
- 2) One of the FCPS nonresettable power outputs (TB4) can be used to supply 24 VDC to M302 terminals 3 and 4 or a separate power source can be used. *The auxiliary power output of the FCPS power supply (TB3 Terminals 8 & 9) should not be used for this purpose.*
- 3) The specific ELR required to be installed on the FCPS trouble monitoring contacts at TB3-3 and TB3-5 is dependent on the particular model of monitor module employed to supervise the FCPS. The Fire-Lite model M300 and M301 require a 47K ELR. The Fire-Lite model M302 requires a 3.9K ELR.
- 4) Do not loop wires under screw terminals. Break wires to maintain proper supervision.
- 5) For a list of compatible devices, refer to Fire-Lite Device Compatibility Document.
- 6) It may be necessary to use an EOL relay on normally activated outputs for proper supervision.

Figure 4-4: Remote Stand-Alone Power Supply

4.5 Remote Power Supply - Resettable and Nonresettable

The FCPS may be used as a remote stand-alone power supply to provide up to an additional 4.0 amps of power to any devices that require filtered, regulated, resettable or nonresettable power. A monitor module may be used to monitor the trouble contact of the FCPS. If the FCPS enters a trouble condition the normally closed contact will open. A resettable output is created by tying the resettable output from the FACP to one or both of the power supply inputs. A nonresettable output is created by cutting an on board resistor (R175 for Output 2, R176 for Output 4). For addressable panel applications, use a monitor module to sense the trouble status of the remote power supply via the trouble relay contact. Cut JP2, R63 and D31 for this application.

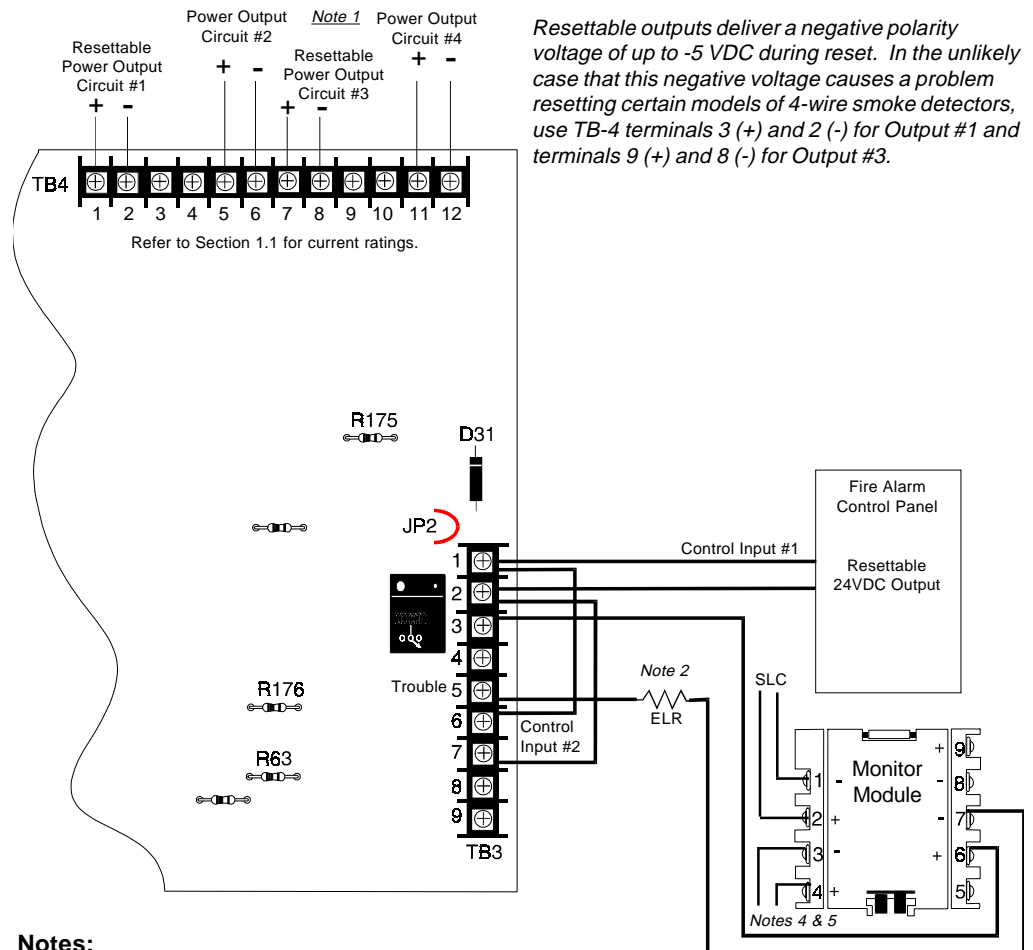

Notes:

- 1) Outputs 2 and 4 are also resettable 24 VDC power in this example. To make Output 2 nonresettable power, cut R175. To make Output 4 nonresettable, cut R176.
- 2) The specific ELR required to be installed on the FCPS trouble monitoring contacts at TB3-3 and TB3-5 is dependent on the particular model of monitor module employed to supervise the FCPS. Fire-Lite models M300 and M301 require a 47K ELR. Fire-Lite model M302 requires a 3.9K ELR.
- 3) Do not loop wires under screw terminals. Break wires to maintain proper supervision.
- 4) If an addressable M302 Monitor Module is employed to monitor the trouble contacts of the remote power supply, the module must be supplied with separate 24 VDC power. This power is required so that the module may supervise the connection to the trouble contacts of the power supply.
- 5) One of the FCPS nonresettable power outputs (TB4) can be used to supply 24 VDC to M302 terminals 3 and 4 or a separate power source can be used. *The auxiliary power output of the FCPS power supply (TB3 Terminals 8 & 9) should not be used for this purpose.*
- 6) For a list of compatible devices, refer to Fire-Lite Device Compatibility Document.
- 7) It may be necessary to use an EOL relay on outputs that are normally activated for proper supervision.

Figure 4-5: One NAC Input - Resettable & Nonresettable Outputs

4.6 Control Module Activation of Output Circuits

This application illustrates the use of addressable control modules instead of Notification Appliance Circuits on an FACP to activate the FCPS remote power supply. Typically, this allows for mounting of the power supply at greater distances from the FACP and expanding the system architecture in various applications.

An addressable control module is used to activate the power supply and an addressable monitor module is used to sense power supply trouble conditions. The Fire•Lite MS-9200 has the capability of locating control and monitor modules up to 10,000 feet away. Cut JP2, R63 and D31 for this application.

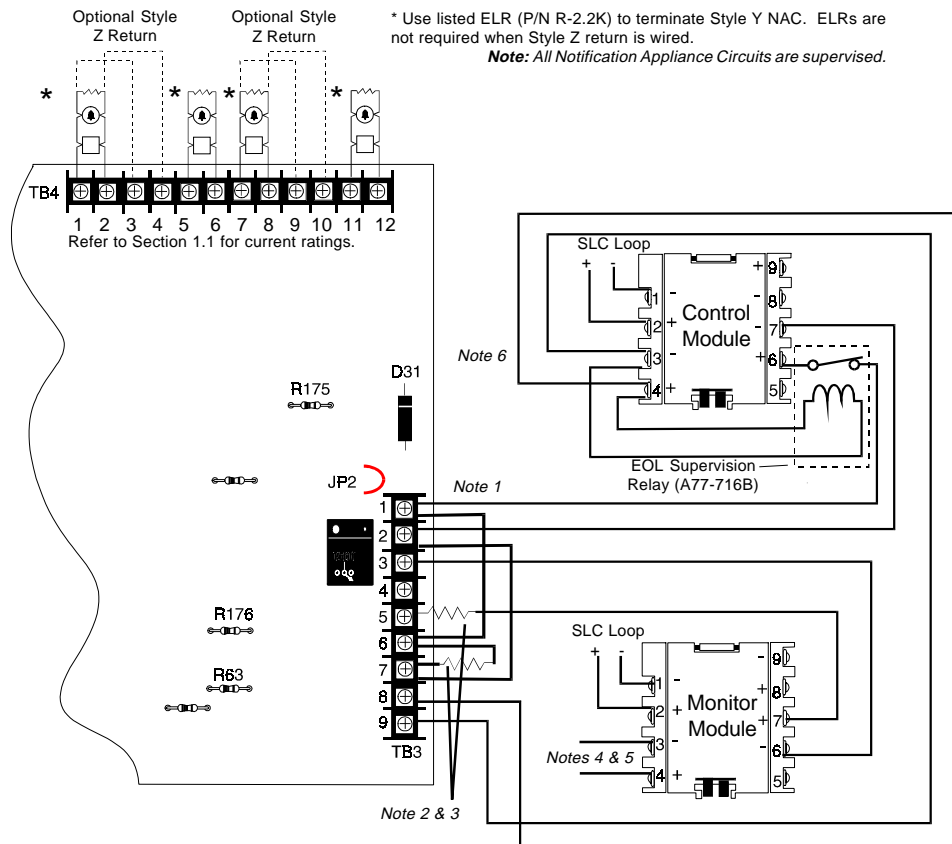

Notes:

- 1) To control all four power supply outputs with one control module, connect output to TB3 Terminals 1 and 2 on the FCPS and jumper Terminal 1 to Terminal 6 and Terminal 2 to Terminal 7.
- 2) An ELR must be installed between Terminals 6 and 7 for control module wiring supervision (the ELR value is dependent on the module employed).
- 3) The specific ELR required to be installed on the FCPS trouble monitoring contacts at TB3-3 and TB3-5 is dependent on the particular model of monitor module employed to supervise the FCPS. Fire-Lite models M300 and M301 require a 47K ELR. Fire-Lite model M302 requires a 3.9K ELR.
- 4) If an addressable M302 Monitor Module is employed to monitor the trouble contacts of the remote power supply, the module must be supplied with separate 24 VDC power. This power is required so that the module may supervise the connection to the trouble contacts of the power supply.
- 5) One of the FCPS nonresettable power outputs (TB4) can be used to supply 24 VDC to M302 terminals 3 and 4 or a separate power source can be used. *The auxiliary power output of the FCPS power supply (TB3 Terminals 8 & 9) should not be used for this purpose.*
- 6) Use EOL relay (A77-716B) to supervise 24 VDC power from the FCPS, TB3 terminals 8 & 9.
- 7) Do not loop wires under screw terminals. Break wires to maintain proper supervision.
- 8) For a list of compatible devices, refer to Fire-Lite Device Compatibility Document.

Figure 4-6: Control Module Activation of Outputs

4.7 Door Release Service

This application illustrates the use of the FCPS to power 24 VDC door holders. A signal must be supplied from the FACP to activate the FCPS's outputs. This signal should consist of a 24 VDC source run through a set of normally closed alarm contacts. During a normal (nonalarm) condition, 24 VDC should be applied to the FCPS. This will result in the outputs of the FCPS being activated which will in turn energize the door holders. When the FACP enters an alarm condition, the relay contact will open and remove the 24 VDC signal from the FCPS, causing the doors to close.

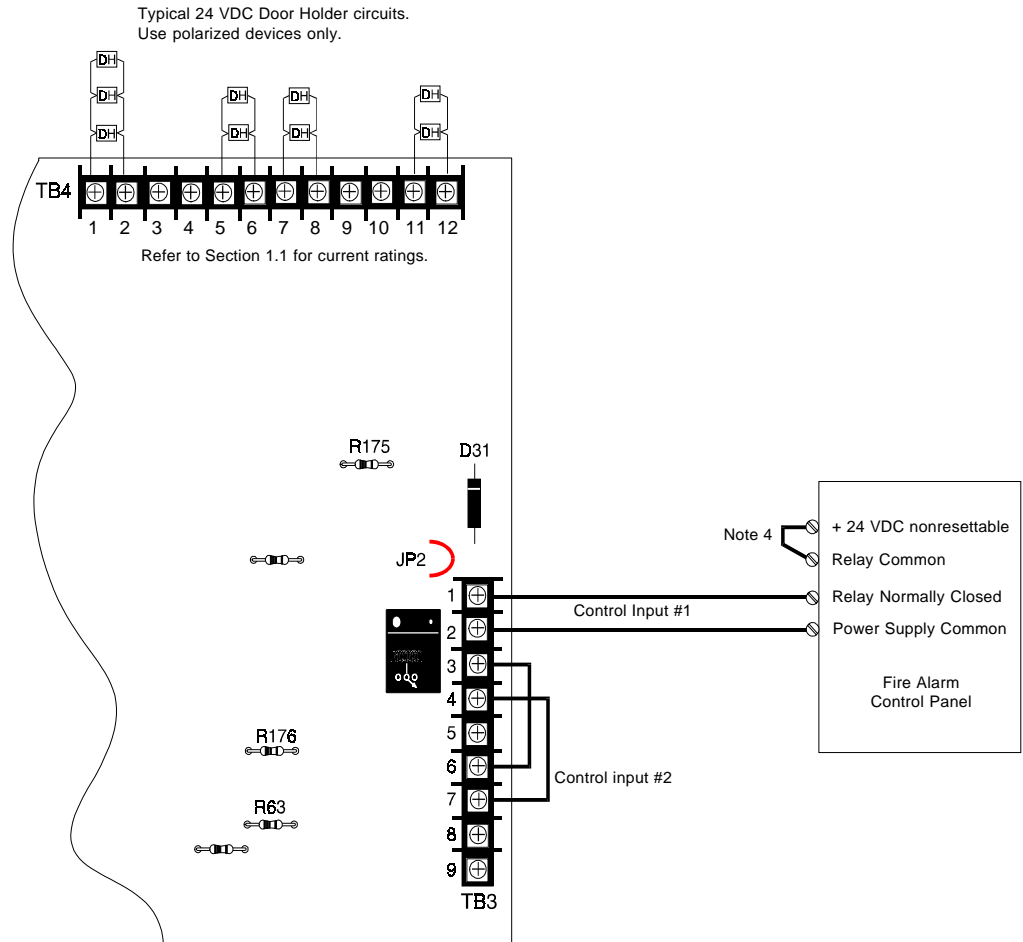

Notes:

- 1) During a normal condition (nonalarm), +24 VDC should be applied to TB3-1 and TB3-2.
- 2) The normally closed alarm relay may consist of an actual relay in the Fire Alarm Control Panel or a control module. If a control module is being used, it may be mounted remotely or at the control panel.
- 3) A monitor module may be used to monitor the trouble contacts of the FCPS.
- 4) Nonresettable power must be used from the FACP.
- 5) A maximum of 4.0 amps may be drawn continuously for holding doors.
- 6) For a list of compatible devices, refer to the Fire-Lite Device Compatibility Document.
- 7) Loss of AC power may cause doors to close due to a momentary power drop while switching over to batteries.

Figure 4-7: Using the FCPS with 24 VDC Door Holders

CHAPTER FIVE

Battery Calculations

5.0 External Device Power

The FCPS provides filtered 24VDC power that may be used for operating Notification Appliance Circuits or other external devices. The power for operating external devices is limited. Use Table 5-1 (standby or nonalarm) and Table 5-2 (alarm) to determine if external loading is within the capabilities of the power supply.

Refer to the device manufacturer's data sheets packaged with each device to find the standby and alarm current draws to use in the tables that follow.

5.1 Device Standby Current Draw

The following table should include the total standby current draw of all devices on each *active* output, including end of line relays when used for supervision.

Device Type	# of Devices		Current (Amps)		Total Current (Amps)
Main PC Board without AC Fail Report Delay Enabled	(1 maximum)	X	0.032		
OR				=	
Main PC Board with AC Fail Report Delay Enabled	(1 maximum)	X	0.048		
MPM-4	[]	X	0.008	=	
EOL Relays	[]	X		=	
Smoke Detectors	[]	X		=	
Smoke Detectors	[]	X		=	
EOL Resistors	[]	X		=	
Annunciators	[]	X		=	
Auxiliary Devices	[]	X		=	
Auxiliary Devices	[]	X		=	
Auxiliary Devices	[]	X		=	
Sum Column for Standby Load				=	Amps

Table 5-1: Load in Standby @24VDC

Current Calculations

1. When Using the 6.0 amps Maximum Current Available:

Five minutes under full load (6.0 amps current draw) requires 3.0 AH of a 7.0 AH capacity battery. The remaining 4.0 AH capacity must support the FCPS during its required standby time. Because of this, the standby current draw cannot exceed the figures listed below:

1) For 24 hour standby time, the standby current draw cannot exceed 0.166 amps at 24 VDC (24 hours x 0.166A) = 3.984 AH

2) For 60 hour standby time, the standby current draw cannot exceed 0.066 amps at 24 VDC (60 hours x 0.066A) = 3.96 AH

3) Standby Current Calculation

Subtract total standby load calculated above from 0.166 amps for 24 hours standby or 0.066 amps for 60 hours standby. This figure should not be less than zero. If the amount is less than zero, the required standby time will not be achieved.

2. When Using Less than 6.0 amps Maximum Current:

Use the following tables to determine the proper battery size.

3. When Battery Amp-Hour Requirements are for Greater than 7.0 AH:

Cut FCPS jumper JP1 to disable onboard battery charger and use an external battery charger.

Device Type	# of Devices		Current (Amps)	Total Current (Amps)
Main PC Board without AC Fail Report Delay Enabled	(1 maximum)	X	0.032	=
OR				
Main PC Board with AC Fail Report Delay Enabled	(1 maximum)	X	0.048	=
MPM-4	[]	X	0.008	
EOL Relays	[]	X		=
Smoke Detectors	[]	X		=
Smoke Detectors	[]	X		=
EOL Resistors	[]	X		=
Annunciators	[]	X		=
Auxiliary Devices	[]	X		=
Auxiliary Devices	[]	X		=
Auxiliary Devices	[]	X		=
Notification Appliances	[]	X		=
Notification Appliances	[]	X		=
Notification Appliances	[]	X		=
Sum Column for Alarm Load				=
				Amps

Table 5-2: Load in Alarm @24VDC

Secondary Power Source Calculations

Use the Total Standby and Alarm Load Currents calculated in Tables 5-1 and 5-2 for the following battery calculation.

Standby Load Current (Amps) []	X	Required Standby Time in Hours (24 or 60 Hours) []	=	_____
Alarm Load Current (Amps) []	X	Required Alarm Time in Hours (i.e. 5 min. = 0.084 hours) []	=	_____
Add Standby and Alarm Load for Required Ampere Hours			=	_____
Multiply by the Derating Factor of 1.2			=	_____
Total Ampere Hours (AH) Required			=	_____

Table 5-3: Secondary Power Source Calculations

Notes:

- 1) Battery size is limited to 7.0 AH using the internal FCPS battery charger.
- 2) For battery sizes greater than 7.0 AH, cut FCPS jumper JP1 to disable the internal battery charger and use an external battery charger.

NOTES

NOTES

NOTES

Limited Warranty

Fire-Lite® warrants its products to be free from defects in materials and workmanship for eighteen (18) months from the date of manufacture, under normal use and service. Products are date stamped at time of manufacture. The sole and exclusive obligation of **Fire-Lite®** is to repair or replace, at its option, free of charge for parts and labor, any part which is defective in materials or workmanship under normal use and service. For products not under **Fire-Lite®** manufacturing date-stamp control, the warranty is eighteen (18) months from date of original purchase by **Fire-Lite®**'s distributor unless the installation instructions or catalog sets forth a shorter period, in which case the shorter period shall apply. This warranty is void if the product is altered, repaired or serviced by anyone other than **Fire-Lite®** or its authorized distributors or if there is a failure to maintain the products and systems in which they operate in a proper and workable manner. In case of defect, secure a Return Material Authorization form from our customer service department. Return product, transportation prepaid, to **Fire-Lite®**, 12 Clintonville Road, Northford, Connecticut 06472-1653.

This writing constitutes the only warranty made by **Fire-Lite®** with respect to its products. **Fire-Lite®** does not represent that its products will prevent any loss by fire or otherwise, or that its products will in all cases provide the protection for which they are installed or intended. Buyer acknowledges that **Fire-Lite®** is not an insurer and assumes no risk for loss or damages or the cost of any inconvenience, transportation, damage, misuse, abuse, accident or similar incident.

Fire-Lite® GIVES NO WARRANTY, EXPRESSED OR IMPLIED, OF MERCHANTABILITY, FITNESS FOR ANY PARTICULAR PURPOSE, OR OTHERWISE WHICH EXTEND BEYOND THE DESCRIPTION ON THE FACE HEREOF. UNDER NO CIRCUMSTANCES SHALL **Fire-Lite®** BE LIABLE FOR ANY LOSS OF OR DAMAGE TO PROPERTY, DIRECT, INCIDENTAL OR CONSEQUENTIAL, ARISING OUT OF THE USE OF, OR INABILITY TO USE **Fire-Lite®** PRODUCTS. FURTHERMORE, **Fire-Lite®** SHALL NOT BE LIABLE FOR ANY PERSONAL INJURY OR DEATH WHICH MAY ARISE IN THE COURSE OF, OR AS A RESULT OF, PERSONAL, COMMERCIAL OR INDUSTRIAL USE OF ITS PRODUCTS.

This warranty replaces all previous warranties and is the only warranty made by **Fire-Lite®**. No increase or alteration, written or verbal, of the obligation of this warranty is authorized.

"**Fire-Lite**" is a registered trademark.



Fire-Lite® ALARMS
INCORPORATED

12 Clintonville Road, Northford, CT 06472
Phone: (203) 484-7161
FAX: (203) 484-7118